

OPERATING INSTRUCTIONS



TYPE 1360-A  
MICROWAVE OSCILLATOR

1360-A

GENERAL RADIO COMPANY

# OPERATING INSTRUCTIONS

# TYPE 1360-A MICROWAVE OSCILLATOR

*Form 1360-0100-A  
April, 1962*

Copyright 1962 by General Radio Company  
West Concord, Massachusetts, USA

G E N E R A L R A D I O C O M P A N Y  
WEST CONCORD, MASSACHUSETTS, USA

## TABLE OF CONTENTS

Section 1. INTRODUCTION . . . . .	1
1.1 Purpose. . . . .	1
1.2 Description . . . . .	1
1.3 Accessories. . . . .	2
1.4 Mounting . . . . .	2
Section 2. OPERATING PROCEDURE. . . . .	2
2.1 Installation . . . . .	2
2.2 Operation. . . . .	2
2.3 Modulation . . . . .	3
Section 3. PRINCIPLES OF OPERATION . . . . .	4
3.1 Reflex Klystron Oscillator . . . . .	4
3.2 Electronic Circuit . . . . .	4
3.3 Output System. . . . .	6
Section 4. SERVICE AND MAINTENANCE . . . . .	7
4.1 General. . . . .	7
4.2 Removal of Instrument from Cabinet. . . . .	7
4.3 Routine Maintenance . . . . .	7
4.4 Trouble-Shooting . . . . .	8
4.5 Tracking Adjustment. . . . .	9
4.6 Mechanical Alignment of Oscillator . . . . .	9
4.7 Klystron Replacement . . . . .	10
4.8 Detector . . . . .	10
4.9 Table of Voltages and Resistances. . . . .	10



Figure 1. Panel view of the Type 1360-A Microwave Oscillator.

## SPECIFICATIONS

### FREQUENCY

**Range:** 1.7 to 4.1 Gc in two ranges, 1.7 to 2.8 Gc and 2.6 to 4.1 Gc.

**Fine Frequency Control ( $\Delta F$ ):** Order of 1 Mc, but not functioning for square-wave modulation.

**Accuracy:**  $\pm 1\%$ .

**Stability:** Warm-up drift is approximately 0.15% during the first hour, total drift approximately 0.25%. After warm-up, frequency is stable within approximately 5 ppm.

**Residual FM:** Approximately 0.5 ppm in the lower frequency range and 0.2 ppm in the higher. Dominant frequencies are 60 and 120 cps (with 60-cycle line frequency).

### OUTPUT POWER

Typically more than 100 mw above 2 Gc. Total variation in maximum output with frequency is 20 to approximately 300 mw.

**Attenuator:** Relative calibration only.

### INTERNAL MODULATION

**Narrow-Band Sweep:** 1 to 3 Mc maximum at 1 kc and power-line frequency. Negative trigger pulse supplied.

**Square-Wave:** 1 kc, adjustable approximately  $\pm 5\%$ .

### EXTERNAL MODULATION

**FM:** Sensitivity approximately 0.2 Mc per volt, input impedance, 400 kilohms and 70 pf (ac only).

**Square-Wave:** 50 cps to 200 kc, 12-v (rms) sine wave or 20-v (peak-to-peak) square wave; 20% minimum duty cycle from external source. Input impedance greater than 100 kilohms.

**Pulse:** Rise and fall times approximately 0.2  $\mu$ sec, minimum length approximately 0.5  $\mu$ sec, jitter may be 0.2  $\mu$ sec. Input impedance 100 kilohms; driving-pulse amplitude, 20 v (peak-to-peak); maximum duty cycle 20%.

### GENERAL

**Terminals:** RF output, TYPE 874 Locking Connector. Modulation, binding posts.

**Mounting:** Bench or relay rack.

**Power Input:** 105 to 125 (or 210 to 250) volts, 50 to 60 cps, 85 watts. Instrument will operate satisfactorily (except for line-frequency sweep) at power-line frequencies up to 400 c.

**Tube Complement:** Two each 6197 and 12AT7, one each 6AN8, 6AV5GA, 12AX7, 12BH7A, 5651, 5836 (Reflex Klystron), 5965.

**Accessories Supplied:** TYPE 874-R22 Patch Cord, TYPE 874-C58 Cable Connector, TYPE CAP-22 Power Cord, and spare fuses.

**Dimensions:** Width 19, height 7½, depth 15½ inches (485 by 195 by 395 mm), over-all; panel, 19 by 7 inches (485 by 180 mm).

**Net Weight:** 38 pounds (17.5 kg).

## SECTION 1

## INTRODUCTION

## 1.1 PURPOSE.

The Type 1360-A Microwave Oscillator (Figure 1) is a general-purpose test oscillator with a frequency range of 1.7 to 4.1 Gc. In addition to its general usefulness as a microwave signal source, its relatively high output power makes this oscillator particularly useful for attenuation and antenna measurements where detector sensitivity is sometimes a problem.

## 1.2 DESCRIPTION.

1.2.1 GENERAL. The oscillator in the Type 1360-A is a Type 5836 reflex klystron in a coaxial cavity with a noncontacting tuning plunger. The frequency range of 1.7 to 4.1 Gc is covered in two modes with internal

mode switches which operate from the main tuning knob. An internal 1-kc RC phase-shift oscillator provides square-wave amplitude modulation and linear frequency sweep over a narrow band. The same sweep can also be obtained at the power-line frequency (50 to 60 cps). For square-wave modulation at other frequencies or for pulse modulation, an external modulator must be used. The Type 1217-B Unit Pulse Generator is recommended for pulse and square-wave modulation and the Type 1210-C Unit RC Oscillator is recommended for square-wave modulation. The EXT FM position of the modulator switch permits ac coupling to the repeller for frequency modulation or sweep.

1.2.2 CONTROLS. The following controls are on the Type 1360-A Microwave Oscillator:

TABLE OF CONTROLS

Name	Type	Function
POWER	Toggle switch	Turns power on or off.
OUTPUT	Continuous rotary control with dial	Output attenuator. Reads db directly at low output only. Watch meter for overcoupling at high output.
METER SENS	Continuous rotary control	Changes sensitivity of output-monitor meter.
$\Delta F$	Continuous rotary control	Fine frequency adjustment. Not operative for square-wave modulation.
SWEEP AMPLITUDE	Continuous rotary control	Changes bandwidth of internal sweep.
1 KC ADJUST	Screw-driver control	Frequency adjustment of internal 1-kc oscillator.
	Eight-position rotary switch	Modulation selector.
	Continuous rotary control with main dial and vernier	Main frequency control. Colored arrows indicate direction to turn for range switching.
1.7-2.8 GC	Red pilot light	Lights when the instrument is operating in the 1.7-to-2.8 Gc range and the red frequency scale should be read.
2.6-4.1 GC	White pilot light	Lights when the instrument is operating in the 2.6-to-4.1 Gc range and the white frequency scale should be read.



TABLE OF CONNECTORS

Name	Type	Function
EXTERNAL MODULATION	Binding post	Input connections for external fm, square-wave, and pulse modulation.
INT. SWEEP TRIGGER OUT	Binding post	Negative trigger output for line-frequency and 1-kc sweep.
OUTPUT	Type 874 Coaxial Connector	Rf output connector.
	Three-terminal male connector	Connection for power line.

1.2.3 CONNECTORS. The above connectors are on the Type 1360-A Microwave Oscillator.

### 1.3 ACCESSORIES.

The Type 1360-A Microwave Oscillator is supplied with a Type 874-R22 Patch Cord, a Type CAP-22 Three-Wire Power Cord, a Type 874-C58 Cable Connector, and spare fuses. Other useful accessories available are attenuator pads and adaptors to other types of coaxial connectors. Refer to the Table of Type 874 Accessories at the rear of this manual.

### 1.4 MOUNTING.

The Type 1360-A Microwave Oscillator is available equipped for either bench or relay-rack mounting. For bench mounting (Type 1360-AM), aluminum end frames are supplied to fit the ends of the cabinet. For rack mounting (Type 1360-AR), special rack-mounting brackets (Type ZSU-3-4) are supplied to attach the cabinet and instrument to the relay rack. These brackets permit either cabinet or instrument to be withdrawn independently of the other. Instructions for installing the Type 1360-AR in a relay rack accompany these brackets.

## SECTION 2

## OPERATING PROCEDURE

### 2.1 INSTALLATION.

A three-wire power cord is supplied with the instrument for connection to the power line. While instruments are normally supplied for 115-volt operation, the power transformer can be reconnected for 230-volt operation (see Figure 12). When changing connections, be sure to reverse the metal plate so that it will indicate 230 volts, and also replace the 2-ampere line fuses with fuses rated at 1 ampere.

### 2.2 OPERATION.

Throw the power switch to POWER, set the modulation switch to CW or any of the internal modulation positions, and set the OUTPUT control to a fairly high value. When the instrument is warmed up, the OUTPUT MONITOR meter will indicate. Figure 2 is a typical frequency-vs-warmup-time curve for the Microwave Oscillator. Although the OUTPUT control should be set to a fairly high setting, too high

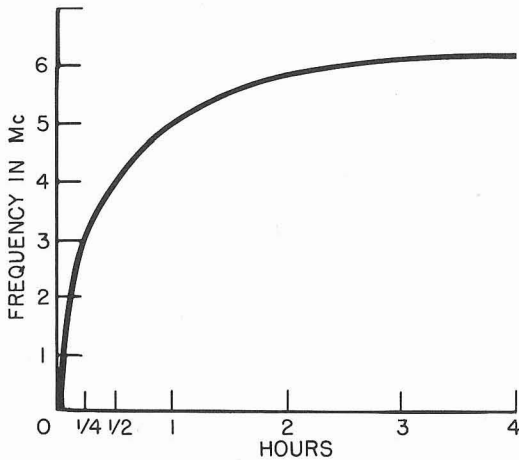

Figure 2. Typical warm-up frequency drift of the Type 1360-A Microwave Oscillator.

a setting might result in overcoupling at some frequencies and the meter will not indicate. Figure 3 is a typical curve for maximum cw output power over the frequency range of the oscillator.

**2.3 MODULATION.**

Select the desired type of modulation using the eight-position rotary switch. The frequency of

the internal 1-kc oscillator can be changed over a narrow range with the 1-KC ADJUST screw-driver control. This oscillator is used for the 1 KC SWEEP and 1 KC  $\square$  positions of the modulation switch.

For the LINE FREQ SWEEP and 1 KC SWEEP positions of the modulation switch, the SWEEP AMPLITUDE control varies the width of the internal narrow-band sweep. Note that the SWEEP AMPLITUDE control does not start at zero. For LINE FREQ SWEEP and 1-KC SWEEP, a negative trigger pulse is available at the INT SWEEP TRIGGER OUT binding post for oscilloscope synchronization.

In the STANDBY position of the modulation switch, the klystron is biased off so that there is no rf voltage at the OUTPUT terminal.

For square-wave modulation (1 KC  $\square$  and EXT  $\square$  positions), the fine frequency adjustment,  $\Delta F$ , does not operate.

Oscillators recommended for external amplitude modulation are the Type 1217-B Unit Pulse Generator for square-wave and pulse modulation, and the Type 1210-C Unit RC Oscillator for square-wave modulation.

Figure 3. Typical maximum output power vs frequency for the Type 1360-A.

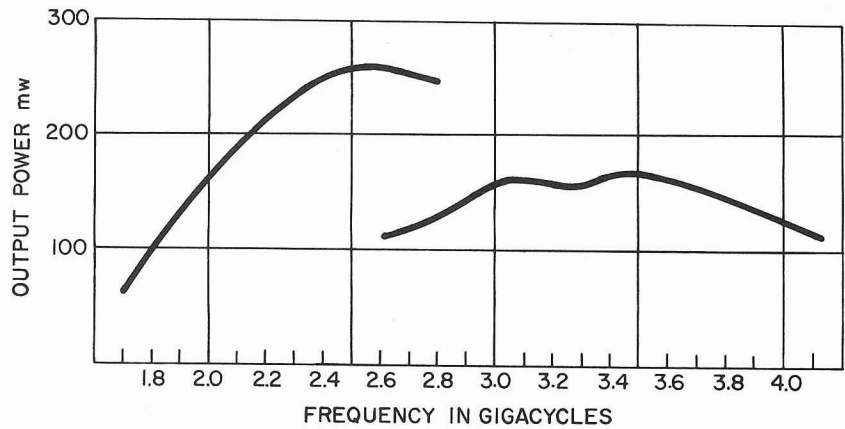



SECTION 3

PRINCIPLES OF OPERATION

3.1 REFLEX KLYSTRON OSCILLATOR.

There are two frequency-determining elements in a reflex klystron: the tuning of the resonant cavity and the repeller voltage of the klystron. These two controls are ganged by driving the repeller potentiometer and the tuning plunger with a common shaft. The resistance card of the potentiometer is shaped to give the correct tuning characteristic. Two modes of oscillation (1.1 and 2.2) cover the range, and the switching is performed with a set of snap-action switches, which are operated by the plunger rack as the frequency dial is turned. The lights on the front panel indicate the active mode, and the arrows over the tuning knob indicate the direction to turn the knob to change modes. To adjust the tracking for differences between tubes, a set of trimming potentiometers, R100 through R104 and R108 through R111, is provided.

3.2 ELECTRONIC CIRCUIT.

3.2.1 GENERAL. As seen in the schematic diagram (Figure 12), the beam voltage and repeller voltage for the klystron are fed from regulated supplies with a common reference tube, V534. The other tubes used in the regulator are V531, V532, V533, V400, and V401. The 10-volt grid voltage for the klystron is controlled by the reference diode, D400.

The modulator consists of a 1-kc RC phase-shift oscillator (one half of V202), a Schmitt trigger circuit (V200 and V201), and a sawtooth generator (V203 and V204), which is preceded by a differentiating stage (half of V202). The three block diagrams (Figures 4, 5 and 6) show how the modulating circuits are employed for various positions of the modulator switch.

3.2.2 EXTERNAL FM MODULATION. With the modulation switch in the EXT FM position, the modulation circuit of the Microwave Oscillator is not used (see Figure 4). The external modulation input is connected to the repeller through a 0.047- $\mu$ f capacitor (C208) across a 470-k $\Omega$  resistor (R232). The shunt capacitance of the repeller circuit is approximately 70 pf. The modulation sensitivity varies over the frequency range and is in the order of 0.2 Mc per volt. The maximum voltage that should be applied is 50 volts peak or 35 volts rms. Voltages greater than this will drive the repeller positive at the low end of both tuning ranges.

3.2.3 LINE-FREQUENCY SWEEP. With the modulation switch set at LINE FREQ SWEEP, a sine-wave signal from the power transformer (winding S9) is clipped in the Schmitt trigger, differentiated, and fed into the sawtooth generator (see Figure 4). The

Figure 4. Block diagram for operation of the Microwave Oscillator with external fm modulation, line-frequency sweep, internal 1-kc sweep, or on cw.

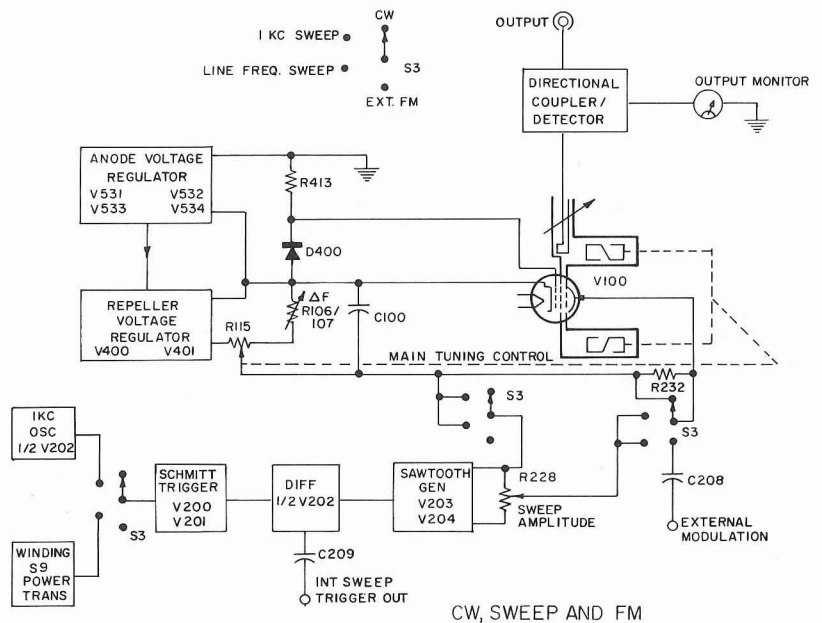
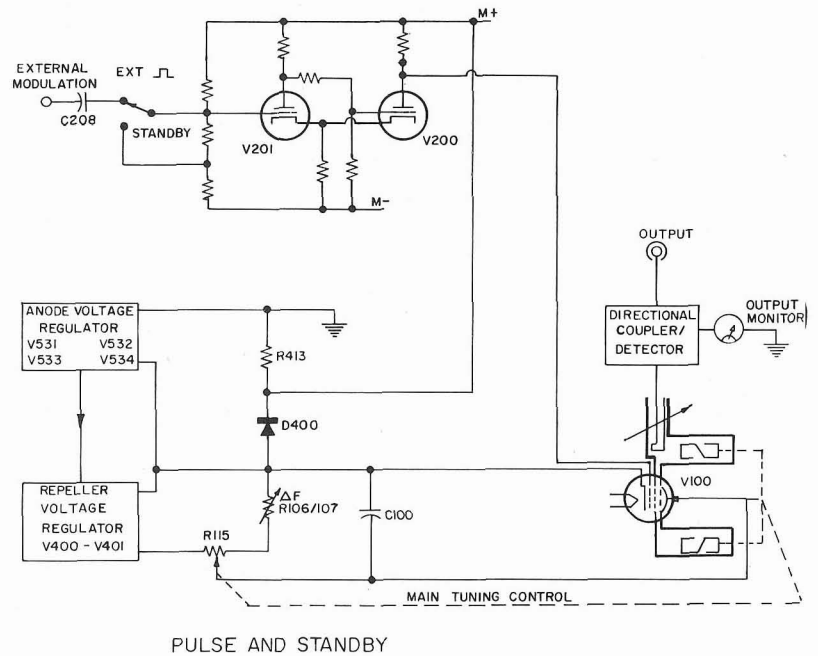



Figure 5. Block diagram for operation of the Microwave Oscillator on standby operation or with external pulse modulation.



sawtooth is approximately 20 volts maximum and the swept bandwidth varies between 2 and 5 Mc. The output is controlled by the SWEEP AMPLITUDE control and is ac-coupled to the repeller. To prevent distortion caused by ripple in the oscillator, a resistor (R415) mounted on switch S3 keeps the sawtooth from dropping to zero value. Over the narrow range the sweep is quite linear in frequency. A negative trigger pulse for oscilloscope synchronization is available from the differentiator at the INT. SWEEP TRIGGER OUT terminal.

3.2.4 INTERNAL 1-KC SWEEP. With the modulation switch in the 1 KC SWEEP position (see Figure 4), the operation is similar to line-frequency sweep (refer

to paragraph 3.2.3) except that the repetition frequency is taken from the internal 1-kc oscillator.

3.2.5 CW OPERATION. With the modulation switch set to CW, the modulator circuit is not used, as shown in Figure 4. To prevent hum pickup the resistor R232 is short-circuited.

3.2.6 STANDBY OPERATION. With the modulation switch set at STANDBY, the control grid of the klystron is connected to the output of the Schmitt trigger circuit and the B+ bus of the modulator is connected to the bias reference diode (see Figure 5). When the first tube in the trigger circuit is biased off, a nega-

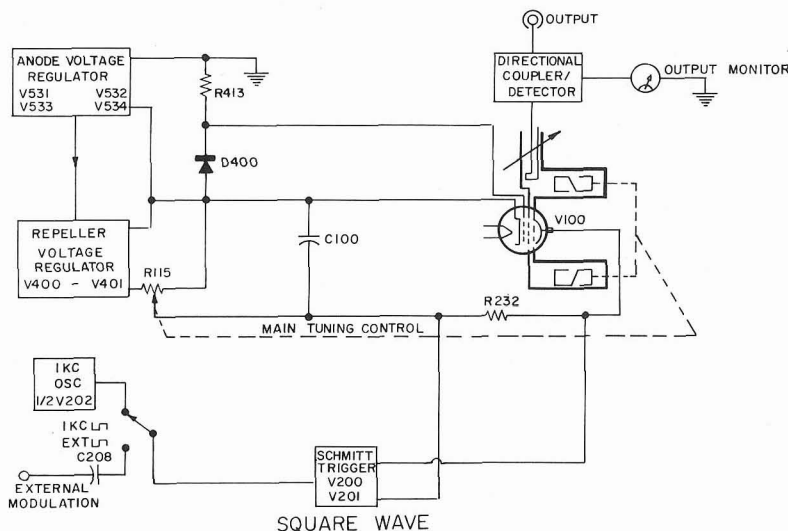

Figure 6. Block diagram for operation of the Microwave Oscillator with internal 1-kc square-wave modulation or external square-wave modulation.



tive voltage developed in the output of the second tube cuts off the beam current of the klystron. This reduces the cathode current from the reflex klystron, but since the heater is on, the operational lifetime of the klystron is not necessarily reduced. The main advantage of the STANDBY switch position is to provide a simple means for turning off the rf power for calibration of external measuring devices.

**3.2.7 1-KC SQUARE-WAVE MODULATION.** In many types of klystrons, including the Type 5836, an appreciable amount of fm occurs across long pulses when the tube is grid-modulated. Therefore, in the Type 1360-A Microwave Oscillator, the repeller is used for square-wave modulation. By modulating in and out of a repeller mode, fm will naturally occur on the leading and trailing edges of the pulse, but its duration is now a function of the switching speed. The 1-kc output from the RC oscillator is fed into the Schmitt trigger circuit where square-wave output is applied across R232 in series with the repeller lead (see Figure 6). The frequency of the 1-kc square wave can be changed with the 1 KC ADJUST screwdriver control to match the frequency of the detector. Figure 7 shows the typical warm-up drift for the 1-kc oscillator. The frequency change with power-line voltage fluctuations is approximately 0.06% per volt at 115 volts.

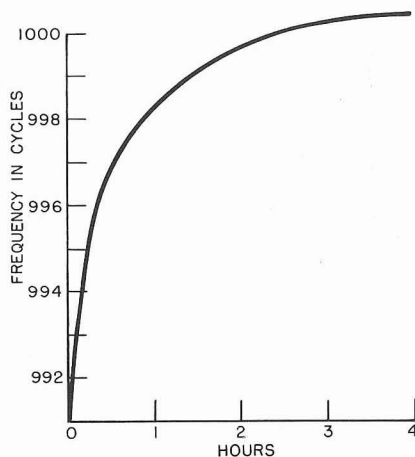

Figure 7. Typical warm-up drift for the 1-kc oscillator.

**3.2.8 EXTERNAL SQUARE-WAVE MODULATION.** For external square-wave modulation, operation is similar to 1-kc square-wave modulation (see Figure 6) except that the modulating voltage is fed from an external source through the EXTERNAL MODULA-

TION connector. The voltage applied may be either at least 12-volt rms sine wave or 20-volt peak-to-peak square wave. Frequencies between 50 cps and 200 kc do not cause appreciable dissymmetry in the output. The symmetry can be adjusted with potentiometer R201 inside the instrument. The Type 1210-C Unit RC Oscillator or 1217-B Unit Pulse Generator is recommended for square-wave modulation of the Type 1360-A Microwave Oscillator.<sup>1</sup>

**3.2.9 EXTERNAL PULSE MODULATION.** For external pulse modulation, the control grid of the klystron is connected to the output of the Schmitt trigger and the B+ bus of the modulator circuit is connected to the bias reference diode, D400 (see Figure 5). A positive pulse of approximately 20 volts peak-to-peak will cause the second tube in the Schmitt trigger circuit to stop conducting, turning on the beam of the klystron. For optimum shape of the rf output pulse, a driving pulse of the smallest possible amplitude should be used. If the duty cycle of the output pulse is too long (greater than 20%), the symmetry control R201 may have to be adjusted.<sup>2</sup>

The Type 1217-B Unit Pulse Generator is recommended as a source for external pulse modulation.

### 3.3 OUTPUT SYSTEM.

The rf energy is picked up with a coupling loop, which is movable in an attenuator tube and controlled by the OUTPUT control. The dial is calibrated to read db when the output is low, i.e., outside the nonlinear region of the attenuator. Since too close coupling to the cavity will overload the oscillator at some frequencies, an output monitor is provided. It consists of a directional coupler with a detector, and a meter that indicates the amount of power into the load. The meter is uncalibrated and serves to indicate the point of highest output at each frequency and shows overcoupling, which is indicated by a reduction in output with increased coupling. (The range where overloading might occur is indicated on the OUTPUT dial). Do not operate the oscillator above the peak in output power because severe pulling then takes place, and the modulation characteristics are degraded.

<sup>1</sup>When the power line is poorly regulated, amplitude stability is improved (with reduced frequency stability, refer to para. 3.2.7) by switching to EXT  and resetting R201.

<sup>2</sup>If the pulse is long, an appreciable frequency change may occur along the pulse. To eliminate this, use the EXT  position of the modulation switch, and adjust R201.

## SECTION 4

## SERVICE AND MAINTENANCE

## 4.1 GENERAL.

The two-year warranty given with every General Radio instrument attests the quality of materials and workmanship in our products. When difficulties do occur, our service engineers will assist in any way possible.

In case of difficulties that cannot be eliminated by the use of these service instructions, please write or phone our Service Department, giving full information of the trouble and of steps taken to remedy it. Be sure to mention the serial and type numbers of the instrument.

Before returning an instrument to General Radio for service, please write to our Service Department or nearest district office (see back cover), requesting a Returned Material Tag. Use of this tag will ensure proper handling and identification. For instruments not covered by the warranty, a purchase order should be forwarded to avoid unnecessary delay.

## 4.2 REMOVAL OF INSTRUMENT FROM CABINET.

Remove the power cable, the two panel screws on each side of the panel, and the two screws in the rear of the instrument. The instrument can then be pulled forward out of the cabinet.

## WARNING

Dangerously high voltages are present inside the instrument. Use great caution when operating the Microwave Oscillator with the cover removed. Use insulated screw-drivers for all adjustments.

## 4.3 ROUTINE MAINTENANCE.

For routine inspection of the operation of the Type 1360-A Microwave Oscillator, observe the swept mode on an oscilloscope when the oscillator is operated with the modulation switch in the 1 KC SWEEP position. In this mode of operation all the electronic circuits are active (see Figure 4) so that most defects will show up. The only test equipment required is a low-frequency oscilloscope and a coaxial detector.

The klystron beam current can be checked with a 50-ma meter at test jack J1 (see Figure 8). This current should be between 15 and 30 ma with the selector switch in the CW position.

Occasionally a drop of clock oil should be applied to moving parts (bearings and pinions).

TABLE 3

Measurement	Voltage	Tubes and Diodes Involved	Adjustment
Klystron Beam Supply	325 volts between chassis or terminal D (positive) and terminals Z or B-.	V531, V532, V533, V534, D300, D301, D302, D303	R551
Klystron Bias Supply	9.5 to 10.5 volts between terminals Y (positive) and Z.	D400	None
Klystron Heater Supply	6.1 to 6.4 volts between Terminals 24 (positive) and Z or B- at 115 (or 230) -volt power line.	D304, D305	None
Repeller Supply	425 volts between Z or B- (positive) and R-.	V400, V401, D310, D311, D312, D313	R411



4.4 TROUBLE-SHOOTING.

4.4.1 KLYSTRON OSCILLATOR AND POWER SUPPLY. Rf-oscillator failure is indicated by a zero or very low reading of the output monitor with the modulation switch set to CW and the most favorable attenuator setting. The fault is 1) in the power supply, 2) in the klystron tube, 3) in the tracking, or 4) in the detector diode.

It is possible, but very unlikely, that the detector diode, D100, is burned out. This can be checked easily by comparison with an external rf detector.

If the beam current (at J1) is between 15 and 30 ma, the failure is probably in the repeller supply or the tracking. If the beam current is not normal, the fault is likely to be in the klystron tube, the beam supply, or the grid bias diode, D400.

Table 3 lists correct voltages for the klystron oscillator. Since there are dangerously high voltages present in the instrument, use great caution when making these measurements.

If the measured voltages agree with those listed in Table 3, but the beam current is not between 15 and 30 ma for cw operation, replace the reflex klystron and readjust the tracking (refer to paragraph 4.5).

If the measured voltages agree with those listed in Table 3 and the beam current is between 15 and 30 ma for cw operation, readjust the tracking (refer to paragraph 4.5). Before readjustment, inspect the mechanical tuning drive to find the cause of the tracking error. For correct mechanical adjustments refer to paragraph 4.6.

4.4.2 MODULATOR. Table 4 lists the correct voltages for the modulator circuit. To make these measurements, a voltmeter with a "floating" cabinet and at least 20,000 ohms-per-volt sensitivity, an oscilloscope, and a pulse generator (General Radio Type 1217-B) are needed.

NOTE. Use great caution when making the following measurements, since all voltages are far removed from ground potential. To simplify the measurements, turn the main frequency dial to 1.7 Gc. At this point, the highest voltage in the instrument at M- is approximately 600 volts from ground and most oscilloscope probes can be used without an external capacitor. A 1000-volt capacitor will give adequate protection regardless of frequency-dial setting.

TABLE 4

Measurement	Voltage	Tubes and Diodes Involved	Adjustments
Power Supply	240 to 260 volts between M+ (positive) and M- with 115 (or 230)-volt power line.	D306, D307, D308, D309	None
1-kc Oscillator	Sine wave (slightly distorted) of at least 12 volts rms at terminal P.	pins 1, 2, and 3 of V202	None
Schmitt Trigger	35 volts peak-to-peak with 115 (or 230)-volt power line at terminal A. Pulse rise time should be less than 0.3 $\mu$ sec; jitter, less than 0.1 $\mu$ sec.	V201, V202	R210, amplitude R201, symmetry C201, overshoot
Sawtooth Generator	Negative trigger pulse should be greater than 50 volts peak-to-peak for 1-kc sweep and 100 volts peak-to-peak for line-frequency sweep at the INT. SWEEP TRIGGER OUT binding post on the panel. Amplitude of sawtooth should be greater than 15 volts peak-to-peak at terminal X.	V203, V204, pins 6, 7, and 8 of V202, D200	None

## 4.5 TRACKING ADJUSTMENT.

4.5.1 GENERAL. As mentioned in Section 3.1, the two frequency-determining elements of the oscillator, the tuned cavity and the repeller voltage, must maintain a fixed relation to each other over the entire frequency range. The procedure of establishing this relation is referred to as "tracking". The procedure outlined in this paragraph assumes that the mechanical alignment between the tuning plunger, snap-action switches, and the dial is correct (refer to Section 4.6), and gives the rules for adjustment of the repeller electrode voltage using the tracking potentiometers located in the left-hand front section of the instrument. Tracking adjustment may be required when the klystron tube is replaced or for maximum performance when the instrument is operated at extreme temperatures.

### WARNING

Use an insulated screwdriver for the following adjustments.

4.5.2 CW, SWEEP, AND EXT FM OPERATION. For this adjustment, operate the oscillator with internal or external sweep. Watch the OUTPUT MONITOR meter and avoid overloading the klystron (refer to paragraph 3.3). Adjust the following controls to obtain a smooth, dome-shaped curve on an oscilloscope over the entire frequency range:

- R111 High end of the 1.7 to 2.8-Gc range
- R101 Low end of the 1.7 to 2.8-Gc range
- R108 High end of the 2.6 to 4.1-Gc range
- R104 Low end of the 2.6 to 4.1-Gc range

Successive adjustments may be required.

4.5.3 PULSE-MODULATED OPERATION. For this adjustment, modulate the oscillator with an external pulse. Watch the OUTPUT dial and be careful not to overload the klystron. Adjust the following controls for an output pulse of high output and good quality:

- R111 High end of the 1.7 to 2.8-Gc range
- R100 Low end of the 1.7 to 2.8-Gc range
- R108 High end of the 2.6 to 4.1-Gc range
- R104 Low end of the 2.6 to 4.1-Gc range

If the setting of R111, R108, or R104 is changed, recheck the cw operation (refer to paragraph 4.5.2).

4.5.4 SQUARE-WAVE OPERATION. To make this adjustment, operate the oscillator with internal 1-kc square-wave modulation or external square-wave modulation. External modulation is recommended to facilitate oscilloscope triggering. To keep track of polarity during the adjustment, offset the symmetry of the applied square wave. The modulator reverses

the square wave so that an applied pulse length,  $t$ , will appear as a pulse length  $(\frac{1}{prf} - t)$  of the rf output pulse.

Starting at the high end of each frequency range, adjust the following controls to obtain an output with a reasonable compromise between maximum output level and modulation quality over the entire frequency range:

- R110 High end of the 1.7 to 2.8-Gc range
- R102 Low end of the 1.7 to 2.8-Gc range
- R109 High end of the 2.6 to 4.1-Gc range
- R103 Low end of the 2.6 to 4.1-Gc range

Successive adjustments may be required.

## 4.6 MECHANICAL ALIGNMENT OF OSCILLATOR.

Some of the dimensions of the klystron cavity are critical and care must be taken when the cavity is reassembled after repair or cleaning. The cavity tuning plunger, repeller voltage, starting point of the repeller tracking potentiometer, mode switches, tuning-shaft stop washers, and frequency dial must be adjusted for coincidence to obtain correct performance. The adjustments should be made in the following sequence:

1. Mode Switches - The position of the mode switches is used as the reference. The factory-set position of these switches should be maintained if possible. However, if the switches are moved, they should be reset so that the switch yoke is 2-23/32" from the tube end-mounting plate.

2. Repeller Potentiometer - The repeller potentiometer, R115, is mounted on the support bracket for the cavity with three Phillips-head captive screws that are accessible through the covered holes in the back of the potentiometer. (Make certain that the wiper arm of the potentiometer is not in the way of the screw-driver.) The arm is continuously adjustable and should be set so that the electrically open position is in the middle of the switching range of the mode switches. The switching range can easily be determined from the vernier dial readings at both ends of the switching sequence. The electrically open position can be checked with an ohmmeter.

3. Tuning Plunger - To adjust the position of the tuning plunger, loosen the setscrew that clamps the fiberglass push rod. Set the plunger so that 4.2 Gc can just be obtained before the mode switches are actuated as the tuning knob is turned counterclockwise. For this adjustment, sweep the oscillator and use a frequency marker from a reference oscillator or wavemeter.

4. Tuning-Shaft Stop Washer - The stops on the tuning shaft are set to prevent any moving part in drive system from being pushed up against its mechanical limit.

5. Repeller Voltage - Track the repeller voltage as described in paragraph 4.5.



6. Frequency Dial - Remove the gear drive with the two screws in front, loosen the frequency dial with its set screws, and set the dial to indicate the correct frequency. Use a reference signal or wavemeter.

4.7 KLYSTRON REPLACEMENT.

To replace the klystron, remove the shield can, unplug the tube socket, and remove the tube retainer with its two captive, spring-loaded screws.

NOTE. Replacement of the klystron may lead to minor calibration errors in the oscillator. If recalibration is desired, contact our Service Department.

4.8 DETECTOR.

The directional-coupler unit with the detector diode is mounted underneath the chassis behind the

output connector. To replace the diode, unscrew the shield cap. To align the directional coupler, loosen the two setscrews (No. 2 spline head) on the side of the unit and twist the base for maximum reading. Also, a satisfactory alignment will usually be obtained if the loop is positioned in the plane of the center conductor with the resistor toward the output connector.

4.9 TABLE OF VOLTAGES AND RESISTANCES.

Table 5 lists test voltages and resistances for aid in trouble-shooting. For these measurements, set the frequency dial of the Type 1360-A Microwave Oscillator to 1.7 Gc and the modulation selector switch to 1 KC SWEEP. Voltages were measured with a vacuum-tube voltmeter, and a line voltage of 115 volts. Resistances given were measured with a Weston Analyzer Model 980. Deviations of up to ±10% from the listed values should not be considered abnormal.

TABLE 5 - VOLTAGE AND RESISTANCE MEASUREMENTS

Tube (Type)	Pin	Dc Volts to terminal M-	Resistance to Ground with terminal M+ shorted to M-	Tube (Type)	Pin	Dc Volts to terminal Z	Resistance to Ground with terminal D shorted to Z, Terminal R+ shorted to R-, and anchor terminal 1 shorted to 12
V200 (6197)	1	94	2k	V100 (5836)	1	10 ±0.5	68k
	2	71	61k		2	6.2	0
	3	252	0		3	0	0
	4	6.3 ac	-		4	0	0
	5	between pins	-	CAP	DO NOT MEASURE	560k	
	6	235	1.2k	V400 (12BH7A)	1	157	3.7M
	7	87	1M		2	-4.7	2.4M
	8	252	0		3	0	0
	9	71	61k		4	6.3 ac	-
			5		to pin 9	-	
V201 (6197)	1	94	2k	6	172	910k	
	2	72	316k	7	82	250k	
	3	252	0	8	88	430k	
	4	6.3 ac	-	9	-	-	
	5	between pins	-	V401 (12AX7)	1	290	47k
	6	210	2k		2	0	2M
	7	87	1M		3	0.6	4M
	8	252	0		4	6.3 ac	-
	9	72	316k		5	to pin 9	-
V202 (12AT7)	1	146	36k	6	88	430k	
	2	-0.4	700k	7	0	0	
	3	1.4	470	8	0.6	4M	
	4	6.3 ac	-	9	-	-	
	5	to pin 9	-	V531 (6AV5GA)	1	308	500k
	6	250	8.2k		2	6.3 ac to pin 7	-
	7	0.2	100k		3	325	0
	8	6.2	10k		4	-	-
	9	-	-		5	442	0
V203 (12AT7)	1	237	8k	6	-	-	
	2	19.4	4.4M	7	147	-	
	3	22.3	10k	8	441	1k	
	4	6.3 ac	-	9	-	-	
	5	to pin 9	-	V532 (6AN8)	1	442	0
	6	19.4	4.4M		2	299	2.5M
	7	-8.4	1M		3	308	490k,
	8	0	0				
	9	-	-				

(Continued)

TABLE 5 (Continued)

Tube (Type)	Pin	Dc Volts to terminal Z	Resistance to Ground with terminal D shorted to Z, Terminal R+ shorted to R-, and anchor terminal 1 shorted to 12
V532 (6AN8) (cont)	4	6.3 ac between pins	-
	5		-
	6	299	2-5M
	7	325	0
	8	196	72k
	9	201	47k
V533 (5965)	1	201	47k
	2	39	540k
	3	42	5.6k
	4	6.3 ac to pin 9	-
	5		-
	6	325	0
	7	36.4	58k
	8	42	5.6k
	9	-	-
V534 (5651)	1	84	66k
	2	0	0
	3	-	66k
	4	-	0
	5	84	66k
	6	-	-
	7	-	0
	8		
	9		



# TYPE 1360-A MICROWAVE OSCILLATOR

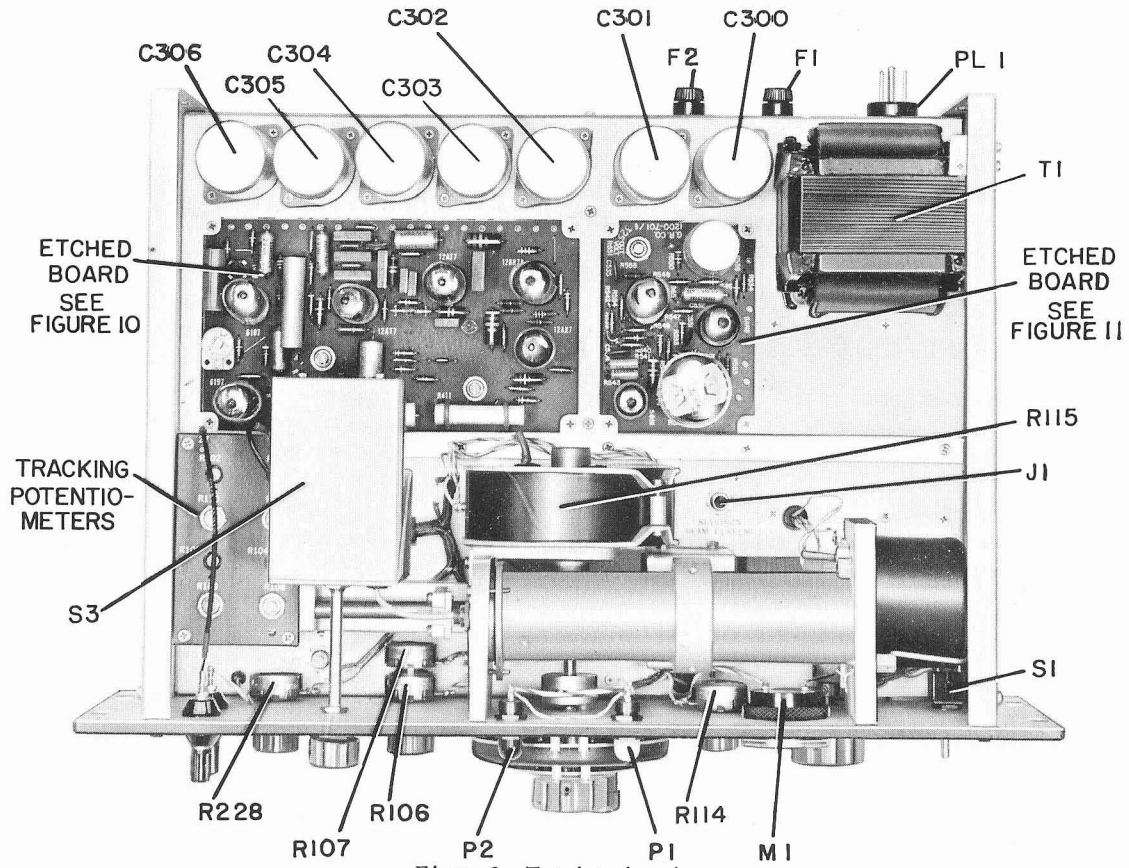

Figure 8. Top interior view.

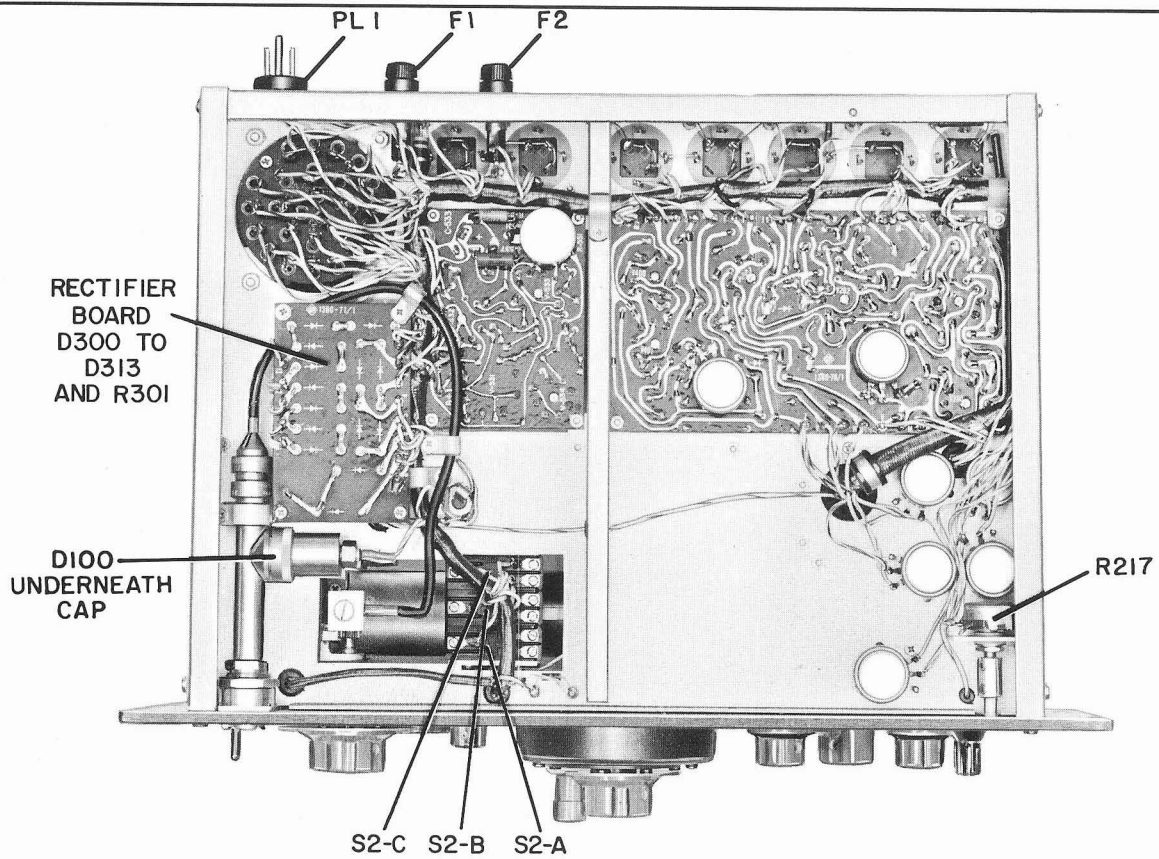

Figure 9. Bottom interior view.





## PARTS LIST

## RESISTORS

R100	50k	±10%		POSC-7(503C)
R101	50k	±10%		POSC-7(503C)
R102	50k	±10%		POSC-7(503C)
R103	100k	±10%		POSC-7(104C)
R104	100k	±10%		POSC-7(104C)
R105	10M	± 5%	1/2 w	REC-20BF(106B)
R106	25k	±10%		1360-410(253C)
R107	50k	±10%		1360-410(503C)
R108	500k	±10%		POSC-11(504C)
R109	500k	±10%		POSC-11(504C)
R110	250k	±10%		POSC-11(254C)
R111	100k	±10%		POSC-11(104C)
R112	15	± 5%	1/2 w	REC-20BF(150B)
R113	100		1/10 w	1360-413
R114	25k	±10%		POSC-25(253C)
R115				977-403
R200	510k	± 5%	1/2 w	REC-20BF(514B)
R201	500k	±20%		POSC-22(504D)
R202	220k	± 5%	1/2 w	REC-20BF(224B)
R203	68k	± 5%	1/2 w	REC-20BF(683B)
R204	390k	± 5%	1/2 w	REC-20BF(394B)
R205	2k	± 5%	5 w	REPO-42(202B)
R206	180k	± 5%	1/2 w	REC-20BF(184B)
R207	2k	± 5%	10 w	REPO-42-2(202B)
R208	2.4k	± 5%	2 w	REC-41BF(242B)
R209	1k	±10%	1 w	REC-30BF(102C)
R210	2.5k	±10%		POSC-11(252C)
R211	1M	± 5%	1/2 w	REC-20BF(105B)
R212	91k	± 5%	1/2 w	REC-20BF(913B)
R213	100	± 5%	1/2 w	REC-20BF(101B)
R214	38.3k	± 1%	1/8 w	REF-60(3832A)
R215	38.3k	± 1%	1/8	REF-60(3832A)
R216	34.8k	± 1%	1/8 w	REF-60(3482A)
R217	25k	±10%		POSC-7(253C)
R218	470	± 5%	1/2 w	REC-20BF(471B)
R219	36k	± 5%	1 w	REC-30BF(363B)
R220	21.5k	± 1%	1/8 w	REF-60(2152A)
R221	3.3M	± 5%	1/2 w	REC-20BF(335B)
R222	100k	± 5%	1/2 w	REC-20BF(104B)
R223	10k	±10%	1 w	REC-30BF(103C)
R224	8.2k	± 5%	1 w	REC-30BF(822B)
R225	750k	± 5%	1/2 w	REC-20BF(754B)
R226	1.1M	± 5%	1/2 w	REC-20BF(115B)
R227	20k	± 5%	1/2 w	REC-20BF(203B)
R228	10k	±10%		POSC-7(103C)
R229	3.3M	± 5%	1/2 w	REC-20BF(335B)
R230	1M	± 5%	1/2 w	REC-20BF(105B)
R231	10k	±10%	1 w	REC-30BF(103C)
R232	470k	± 5%	1/2 w	REC-20BF(474B)
R233				REU-8(
R300	33	± 5%	5 w	REPO-43(330B)
R301	1	± 5%	10 w	REPO-44(010B)
R302	1.8	± 5%	10 w	REPO-44(018B)
R303	1.8	± 5%	10 w	REPO-44(018B)
R304	620	± 5%	5 w	REPO-43(621B)
R305	620	± 5%	5 w	REPO-43(621B)
R306	270	± 5%	3 w	REPO-45(271B)
R400	2M	± 5%	1/2 w	REC-20BF(205B)
R401	330k	± 5%	1/2 w	REC-20BF(334B)
R402	1M	± 5%	1/2 w	REC-20BF(105B)
R403	1M	± 5%	1/2 w	REC-20BF(105B)
R404	430k	± 5%	1/2 w	REC-20BF(434B)
R405	47k	± 5%	2 w	REC-41BF(473B)
R406	4.3M	± 5%	1/2 w	REC-20BF(435B)
R407	120	± 5%	1/2 w	REC-20BF(121B)
R408	120	± 5%	1/2 w	REC-20BF(121B)
R409	270k	± 5%	1 w	REC-30BF(274B)
R410	1k	± 5%	1/2 w	REC-20BF(102B)
R411	1M	±10%		POSC-11(105C)
R412	2.7M	± 5%	1/2 w	REC-20BF(275B)
R413	68k	± 5%	2 w	REC-41BF(683B)
R414	3.9M	± 5%	1/2 w	REC-20BF(395B)
R415	1.8k	± 5%	1/2 w	REC-20BF(182B)
R531	1k	± 5%	1/2 w	REC-20BF(102B)
R532	1k	± 5%	1/2 w	REC-20BF(102B)

## RESISTORS (Continued)

R533	9.1M	± 5%	1/2 w	REC-20BF(915B)
R534	2.7M	± 5%	1/2 w	REC-20BF(275B)
R535	120k	± 5%	1/2 w	REC-20BF(124B)
R536	2.2M	± 5%	1/2 w	REC-20BF(225B)
R537	287k	± 1%	1/2 w	REF-70(2873A)
R538	390k	± 5%	1/2 w	REC-20BF(394B)
R539	100k	± 5%	1/2 w	REC-20BF(104B)
R540	6.2M	± 5%	1/2 w	REC-20BF(625B)
R541	75k	± 1%	1/4 w	REF-65(753A)
R542	1k	± 5%	1/2 w	REC-20BF(102B)
R543	100k	± 1%	1/4 w	REF-65(104A)
R544	91k	± 5%	1 w	REC-30BF(913B)
R545	47k	± 5%	1/2 w	REC-20BF(473B)
R546	180k	± 5%	1/2 w	REC-20BF(184B)
R547	1k	± 5%	1/2 w	REC-20BF(102B)
R548	5.6k	± 5%	1/2 w	REC-20BF(562B)
R549	1.5M	± 5%	1/2 w	REC-20BF(155B)
R550	470k	± 5%	1/2 w	REC-20BF(474B)
R551	10k	±10%		POSW-3(103C)
R552	33k	± 1%	1/4 w	REF-65(333A)
R553	10M	± 5%	1/2 w	REC-20BF(106B)
R554	100	± 5%	1/2 w	REC-20BF(101B)
R555	100	± 5%	1/2 w	REC-20BF(101B)

## CAPACITORS

C100	1µf	±10%	400 dcwv	COP-25(105C)
C101	2500	GMV		FIE-1(252C)
C102	2500	GMV		FIE-1(252C)
C103	2500	GMV		FIE-1(252C)
C104	0.0003µf			
C105	50	±10%		FIE-2(500C)
C200	0.047µf	±10%	400 dcwv	COW-25(473C)
C201	7 to 45			COT-12
C202	0.1µf	±10%	200 dcwv	COW-16(104C)
C203	0.0051µf	± 1%	100 dcwv	COM-5F(512A)
C204	0.0051µf	± 1%	100 dcwv	COM-5F(512A)
C205	0.0051µf	± 1%	100 dcwv	COM-5F(512A)
C206	0.047µf	±10%	400 dcwv	COW-25(473C)
C207	0.0051µf	± 1%	100 dcwv	COM-5F(512A)
C208	0.047µf		1000 dcwv	1360-49
C209	0.047µf		1000 dcwv	1360-49
C210	0.0001µf	± 5%	500 dcwv	COM-22B(101B)
C211	0.0015µf	± 5%	100 dcwv	COM-22B(152B)
C212	0.22µf	±10%	100 dcwv	COW-17(224C)
C213	0.047µf	±10%	400 dcwv	COW-25(473C)
C214	0.0091µf	± 5%	500 dcwv	COM-1D(912B)
C215	0.000562µf	± 5%	300 dcwv	COM-22D(5620B)
C300A	90			
C300B	30		300 dcwv	COE-52
C300C	30			
C301A	90			
C301B	30		300 dcwv	COE-52
C301C	30			
C302A	1500			
C302B	750		15 dcwv	COE-9
C302C	750			
C303A	1500			
C303B	750		15 dcwv	COE-9
C303C	750			
C304A	50			
C304B	25		450 dcwv	COE-10
C304C	25			
C305A	50			
C305B	25		450 dcwv	COE-10
C305C	25			
C306A	50			
C306B	25		450 dcwv	COE-10
C306C	25			
C400	0.22µf	±10%	600 dcwv	COP-25(224C)
C531	0.001µf	±20%	500 dcwv	COC-61(102D)
C532	0.047µf	±10%	400 dcwv	COW-25(473C)
C533	20µf		450 dcwv	COE-5
C534	0.01µf	±20%	500 dcwv	COC-63(103D)
C535	0.01µf	±20%	500 dcwv	COC-63(103D)

## PARTS LIST (Continued)

DIODES	
D100	2REM1002/1N23B
D200	2RED1003/1N34A(S)
D300, D301, D302 } D303	2RE1002/1N3254
D304, D305	2RE1001/1N3253
D306, D307, D308, } D309, D310, D311, } D312, D313	2RE1002/1N3254
D400	2REZ1012/1N758A

FUSES	
F1	115 v      230 v FUF-1, 2a    FUF-1, 1a
F2	FUF-1, 2a    FUF-1, 1a

JACKS	
J1	CDSJ-10    J3    BP-5B
J2	BP-5B      J4    BP-10, 11/16

MISCELLANEOUS		
P1	Pilot Lamp	SOL-14
P2	Pilot Lamp	SOL-14-2
PL1	Plug	CDPP-10
M1	Meter	MEDS-94
T1	Transformer	365-404

SWITCHES			
S1	SWT-333	S2C	1360-412
S2A	1360-412	S3	SWRW-198
S2B	1360-47		

TUBES			
V100	5836	V401	12AX7
V200	6197	V531	6AV56A
V201	6197	V532	6AN8
V202	12AT7	V533	5965
V203	12AT7	V534	5651
V400	12BH7A		

### NOTES

All resistances are in ohms, unless otherwise indicated by k (kilohms) or M (megohms).

All capacitances are in picofarads, unless otherwise indicated by  $\mu$ f (microfarads).

Type designations for resistors and capacitors are as follows:

COC - Capacitor, ceramic	POSC - Potentiometer, composition
COE - Capacitor, electrolytic	POSW - Potentiometer, wire-wound
COM - Capacitor, mica	REC - Resistor, composition
COP - Capacitor, plastic	REF - Resistor, film
COT - Capacitor, trimmer	REPO - Resistor, power
COW - Capacitor, wax	
FIE - Filter	

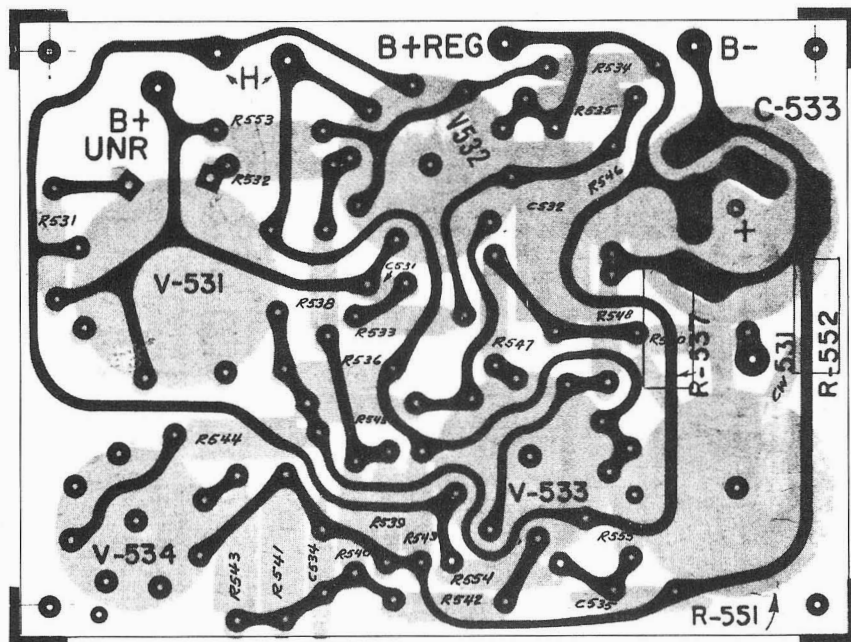
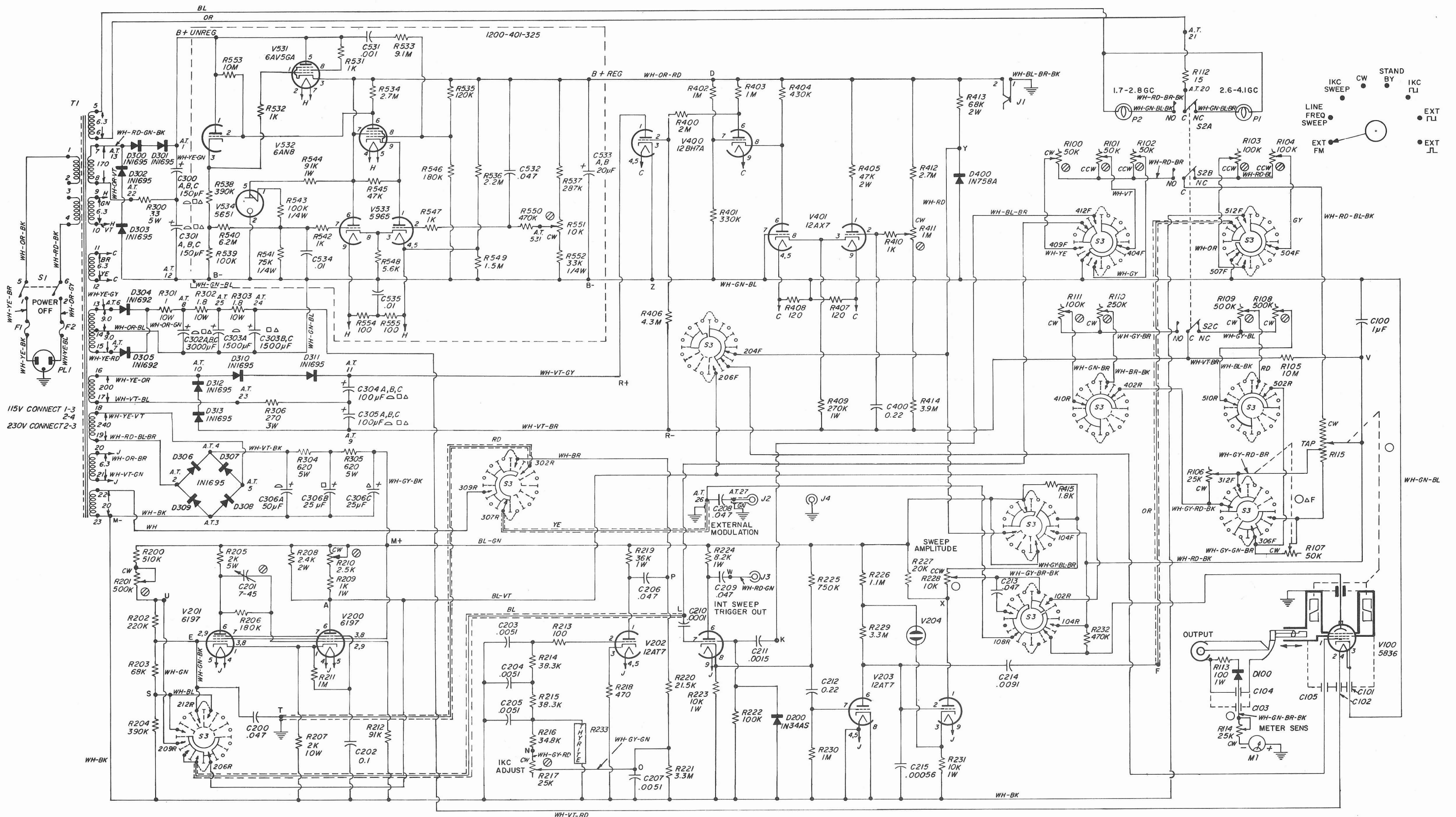

Figure 11. Beam-voltage regulator etched board.



NOTES:  
 RESISTORS 1/2 WATT UNLESS OTHERWISE SPECIFIED  
 RESISTANCE IN OHMS UNLESS OTHERWISE SPECIFIED  
 K=1000 OHMS M=1 MEGOHM

CAPACITANCE VALUES ONE AND OVER IN PICOFARADS,  
 LESS THAN ONE IN MICROFARADS, UNLESS OTHERWISE SPECIFIED

○ KNOB CONTROL  
 ⊗ SCREWDRIER CONTROL

Figure 12. Schematic diagram for the Type 1360-A Microwave Oscillator.

### TYPE 874 COAXIAL COMPONENTS

TYPE 874- CONNECTORS						OTHER COAXIAL ELEMENTS	
CONNECTOR TYPE	CABLE TYPE					Type 874-	
	874-A2	874-A3 RG-29/U RG-55/U RG-58/U RG-58A/U	RG-8/U	RG-9/U RG-116/U	RG-59/U RG-116/U		
CABLE	-C	-C58	-C8	-C9	-C62	A2	50 Ω cable (low loss)
CABLE LOCKING	-CL	-CL58	-CL8	-CL9	-CL62	A3	50 Ω cable
PANEL	-P	-P58	-P8	-P8	-P62	D20, D50	20-, 50-cm adjustable stubs
PANEL, FLANGED	-PB	-PB58	-PB8	-PB8	-PB62	EL	90° ell
PANEL, LOCKING	-PL	-PL58	-PL8	-PL8	-PL62	F185	185-Mc low-pass filter
PANEL, LOCKING RECESSED	-PRL	-PRL58	-PRL8	-PRL8	-PRL62	F500	500-Mc low-pass filter
Example: For a locking cable connector for RG-8/U, order Type 874-CL8.						F1000	1000-Mc low-pass filter
						F2000	2000-Mc low-pass filter
						F4000	4000-Mc low-pass filter
						G3, G6	3-, 6-, 10-, & 20-db attenuators
						G10, G20	
						GA	adjustable attenuator
						JR	rotary joint
						K	coupling capacitor
						L10, L20, L30	10-, 20-, & 30-cm rigid air lines
						LA	
						LK10, LK20	33-58 cm adjustable line constant-Z adjustable lines
						LR	radiating line
						LT	trombone constant-Z line
						M	component mount
						MB	coupling probe
						MR	mixer-rectifier
						T	tee
						UB	balun
						VC	variable capacitor
						VI	voltmeter indicator
						VQ	voltmeter detector
						VR	voltmeter rectifier
						W100	100-Ω termination
						W200	200-Ω termination
						WM	50-Ω termination
						WN, WN3	short-circuit terminations
						WO, WO3	open-circuit terminations
						X	insertion unit
						Y	cliplock
						Z	stand
<p style="margin: 0;">*Locking Type 874 Connector,</p> <p style="margin: 0;">Example: To connect Type 874 to a Type N jack, order Type 874-QNP.</p>						<p style="margin: 0;">The above is a partial listing. For complete details, refer to the General Radio catalog.</p>	

#### TYPE 874- ADAPTORS

TO TYPE	874-	TO TYPE	874-
BNC plug	QBJA	TNC plug	QTNJ
jack	QBJL* QBPA	jack	QTNJL* QTNP
C plug	QCJA	UHF plug	QUJ
jack	QCJL* QCP	jack	QUJL* QUP
HN plug	QHJA	UHF 7/8-in.	QU1A
jack	QHPA	Air 1-5/8-in.	QU2
LC plug	QLJA	Line 3-1/8-in.	QU3A
LT plug	QLTJ	<p style="margin: 0;">*Locking Type 874 Connector,</p> <p style="margin: 0;">Example: To connect Type 874 to a Type N jack, order Type 874-QNP.</p>	
jack	QLTP		
N plug	QNJA		
jack	QNJL* QNP		
SC plug	QSCJ		
jack	QSCJL* QSCP		

# GENERAL RADIO COMPANY

WEST CONCORD, MASSACHUSETTS

EMERSON 9-4400

MISSION 6-7400

## DISTRICT OFFICES

### NEW YORK

Broad Ave. at Linden, Ridgefield, N. J.  
Telephone N.Y. WOrth 4-2722  
N.J. WHitney 3-3140

### SYRACUSE

Pickard Bldg.  
East Molloy Rd., Syracuse 11, N. Y.  
Telephone GLenview 4-9323

### PHILADELPHIA

1150 York Rd., Abington, Penna.  
Telephone TURner 7-8486  
Phila., HANcock 4-7419

### WASHINGTON

8055 13th St., Silver Spring, Md.  
Telephone JUNiper 5-1088

### FLORIDA

113 East Colonial Drive, Orlando, Fla.  
Telephone GARDen 5-4671

### CHICAGO

6605 West North Ave., Oak Park, Ill.  
Telephone VILLage 8-9400

### LOS ANGELES

1000 N. Seward St., Los Angeles 38, Calif.  
Telephone HOLlywood 9-6201

### SAN FRANCISCO

1186 Los Altos Ave., Los Altos, Calif.  
Telephone WHitecliff 8-8233

### CANADA

99 Floral Pkwy., Toronto 15, Ont.  
Telephone CHerry 6-2171

## REPAIR SERVICES

### EAST COAST

General Radio Company  
Service Department  
22 Baker Ave., W. Concord, Mass.  
Telephone EMERSON 9-4400

### NEW YORK

General Radio Company  
Service Department  
Broad Ave. at Linden, Ridgefield, N. J.  
Telephone N.Y. WOrth 4-2722  
N.J. WHitney 3-3140

### MIDWEST

General Radio Company  
Service Department  
6605 West North Ave., Oak Park, Ill.  
Telephone VILLage 8-9400

### WEST COAST

General Radio Company  
Service Department  
1000 N. Seward St.  
Los Angeles 38, Calif.  
Telephone HOLlywood 9-6201

### CANADA

General Radio Company  
Service Department  
99 Floral Pkwy., Toronto 15, Ont.  
Telephone CHerry 6-2171

General Radio Company (Overseas), Zurich, Switzerland  
Representatives in Principal Overseas Countries